

FHZD Installation, Testing and Maintenance Instructions

CAUTION: Installation of Backflow Preventers must be performed by qualified, licensed personnel. The installer should be sure the proper device has been selected for the particular installation. Faulty installation could result in an improperly functioning device.

The Zenner Model FHZD Hydrant Backflow Meter consists of a 3" Hydrant Meter and integral Reduced Pressure Principle Backflow Preventer for use on water lines where usage must be metered and a health hazard could exist if a backflow situation were to occur.

Proper performance is dependent upon following these installation instructions and prevailing governmental and industry standards and codes. Failure to do so, according to Zenner's Limited Warranty "...releases Zenner of any liability that it might otherwise have with respect to that device." Such failure could also result in an improperly functioning device.

Damage to the device could result wherever water hammer and/or water thermal expansion could create excessive line pressure. Where this could occur, shock arresters and/or pressure relief valves should be installed downstream of the device.

1. Before installing a Model FHZD, flush the line thoroughly to remove all debris, chips and other foreign matter. If required, a strainer should be placed upstream of the Hydrant Backflow Meter.
2. The Model FHZD must be installed in a horizontal position to provide proper operation of the relief valve.
3. If installation of a Model FHZD is in a building, provide a suitable drain arrangement to drain off spillage from the relief valve.
4. Install valve at least 12 inches above surrounding flood level.
5. Always consult local codes for installation methods, approvals and guidance.
6. Zenner Model FHZD Hydrant Backflow Meters must be protected against freezing conditions. Exposure to freezing conditions will result in improper function or damage to the device. The installation location must be kept above 32°F. All the basic installation instructions apply.

SPECIFICATIONS:

Maximum intermittent flow rate	650 GPM
Maximum continuous flow rate	450 GPM
Minimum flow rate	2-1/2 GPM
Maximum working water pressure	175 PSI
Maximum working water temperature	140°F
Hydrostatic test pressure	350 PSI
Fire Department connection (2-1/2")	NSFHT

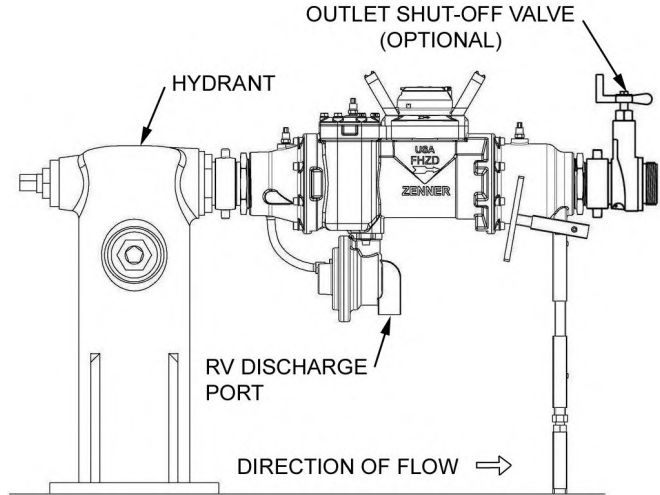

TYPICAL INSTALLATION
Zenner Model FHZD
Hydrant Backflow Meter

PLACING THE DEVICE IN SERVICE

After the installation of a Model FHZD has been completed, place the unit in service as follows:

1. Start with the hydrant closed. Slowly open the hydrant until the FHZD is completely pressurized. A brief discharge from the relief valve may occur while the device is pressurizing. The discharge should cease by the time the hydrant is fully open. If the discharge does not stop, refer to "MAINTENANCE INSTRUCTIONS" for repair procedures.
2. If the FHZD has been equipped with optional downstream shut-off valve wait until device has completely pressurized then vent all trapped air from both check valves by slightly opening each of the three test cocks.
3. The Model FHZD is now in service.
4. If "spitting" of intermittent discharges from the relief valve are noted, it could be a result of pressure fluctuations and/or a water hammer condition in the system..

FHZD Testing Procedures

TEST NO. 1 - RELIEF VALVE OPENING POINT

REQUIREMENT:

The differential pressure relief valve must operated to maintain the zone between the two check valves at least 2 psi less than the supply pressure.

Note: It is recommended that testing be conducted in meter shop.

PROCEDURE:

1. Slowly flush water through test cocks #1, #2 and #3 by opening and closing each test cock one at a time.
2. Install appropriate fittings to test cocks. Attach hose from the high side of the differential pressure gauge to the #1 test cock then attach hose from the low side of the gauge to the #2 test cock. Open test cock #2 slowly and then bleed all air from the hose and gauge by opening the low side bleed needle valve.
3. Maintain the low side bleed needle valve in the open position while test cock #1 is opened slowly. Open the high side bleed needle valve to bleed all air from the hose and gauge. Close the high side bleed needle valve, then close the low side bleed needle valve after the gauge reading has reached the upper end of the scale.
4. Close the downstream shut-off valve.
5. Open the high side control needle valve approximately one turn, and then open the low side control needle valve no more than 1/4 turn. Observe the differential pressure reading as it slowly drops to the relief valve opening point. Record this opening point value when the first discharge of water is detected. Close the low side needle valve.

TEST NO. 2 - TIGHTNESS OF #2 CHECK VALVE

REQUIREMENT:

The #2 check valve shall be tight against backpressure.

PROCEDURE:

1. Vent all air through the vent hose by opening the vent needle valve. Close the vent needle valve only (The high side control needle valve is to remain open).
2. Attach the vent hose to the #3 test cock, then open the #3 test cock. Bleed water from the zone by opening the low side bleed needle valve. Once the gauge reading reaches a value above the #1 check valve pressure drop, close the low side bleed needle valve.
3. Open the vent needle valve. If the indicated differential pressure reading remains steady then the #2 check valve is reported as "closed tight." If the differential pressure reading falls to the relief valve opening point, bleed water through the low side bleed needle valve until the gauge reading reaches a value above the #1 check valve pressure drop. If the gauge reading settles above the relief valve opening point, record the #2 check valve as "closed tight".

Note: Due to disc compression, you may need to bleed off water through low side bleed needle valve several times before the gauge reading will settle above relief valve opening point.

TEST NO. 3 - TIGHTNESS OF #1 CHECK VALVE

REQUIREMENT:

The static pressure drop across #1 check valve shall be greater than the relief valve opening point (Test #1), and at least 5.0 psid.

PROCEDURE:

1. With the vent hose connected to test cock #3 as in step 3 of Test #2, bleed water from the zone through the low side bleed needle valve on the gauge until the reading exceeds the #1 check valve pressure drop. Close the low side bleed needle valve. After the gauge reading settles, the steady state differential pressure reading indicated is the actual static pressure drop across check valve #1 and is to be recorded as such.
2. Close all test cocks, slowly open downstream shutoff valve and remove equipment.

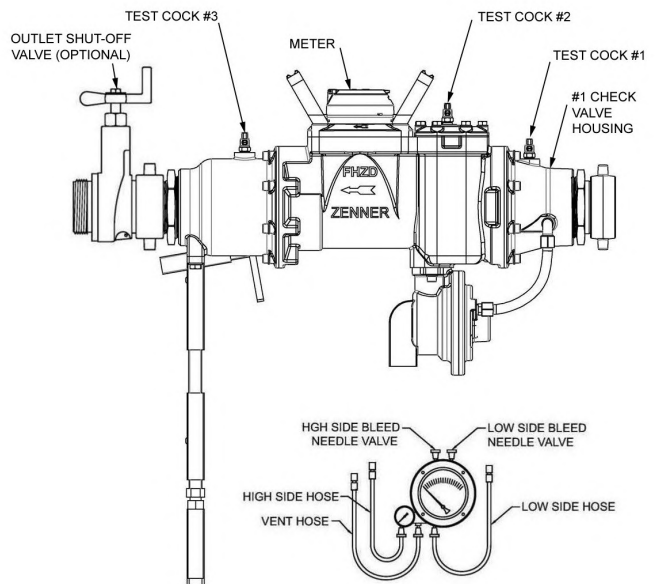

FHZD Maintenance Instructions

All Model FHZD Hydrant Backflow Meters must be inspected and maintained at least once a year or more frequently as specified by local codes. Replacement of worn or damaged parts must only be made with genuine "Zenner" parts. The Zenner Certificate of Limited Warranty provides that failure to do so releases Zenner of any liability that it might otherwise have with respect to that device." Such failure could also result in an improperly functioning device.

The Model FHZD Hydrant Backflow Meter should be thoroughly flushed after backflow conditions occur to prevent any type of corrosive deterioration to its components. Failure to do so could result in malfunction of the device.

Note: It is recommended that all valve maintenance be completed in meter shop.

GENERAL MAINTENANCE

1. Clean all parts thoroughly with water after disassembly.
2. Carefully inspect rubber seal rings, diaphragms and o-rings for damage.
3. Test unit after reassembly for proper operation (see "Testing Procedures").

SERVICING CHECK VALVES

1. Close hydrant and downstream shut-off valves.
2. Open No. 1, No. 2 and No. 3 test cocks to release pressure from valve.
3. Prior to removing the #1 check housing, disconnect the sensing hose.
4. Remove check housings from main body.
5. Remove the checks from the housings.

Note: Always service the checks one at a time to avoid mixing parts.

6. Start by removing the hardware and o-rings from the back of the check assembly (See "Check Valve Assembly" illustration). Separate the seal retainer from the assembly to expose the seal ring.
7. Inspect the seal ring for cuts or embedded debris. If the reverse side of the seal is unused, the seal ring can be inverted and used temporarily until a new seal is obtained. Inspect seat o-ring and replace if cut or damaged in any way.
8. Inspect valve cavity and seating areas. Flush with water to remove any debris.
9. Reverse the above procedures to reinstall check valve assembly.

Note: Apply a light coating of an appropriate lubricant to the large check o-rings on check #1 and #2.

10. Close any remaining open test cocks and place valve back in service.

SERVICING RELIEF VALVE

1. Remove relief valve cover bolts and cover. Gently pull on diaphragm to remove the cartridge assembly.
2. Inspect seal ring for cuts and embedded debris. Turn over or replace if required.
3. Disassemble cartridge by unscrewing relief valve retaining screw.
4. Inspect diaphragm and o-rings for damage. Replace required parts and apply a light coat of grease to plunger o-ring.
5. Carefully reassemble cartridge assembly.
6. Inspect relief valve seat for wear on seating surface. If damaged, replace seat and seat o-ring.
7. Insert cartridge assembly into relief valve body.
8. Replace relief valve cover and cover bolts.
9. Place device in service and test per "TESTING PROCEDURES".

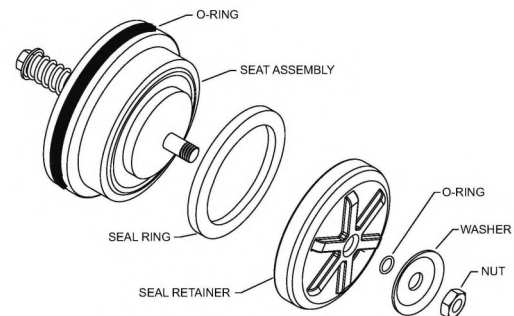
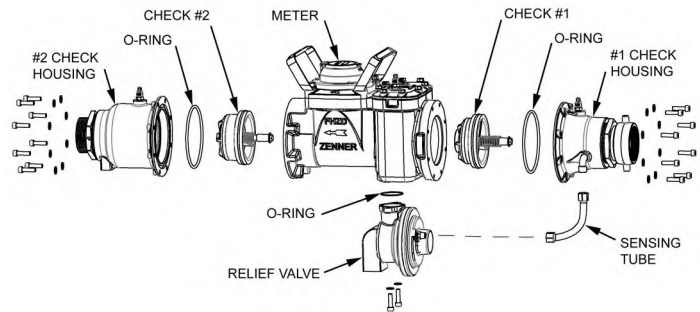

CHECK VALVE ASSEMBLY

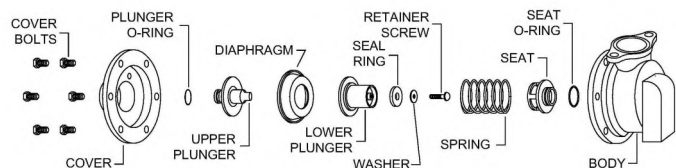

RELIEF VALVE ASSEMBLY

FHZD Troubleshooting

When the relief valve discharges intermittently it can be almost always assumed that the device is functioning correctly and that the discharge is caused by systems such as inlet pressure fluctuations or water hammer due to quick closing valves.

PROBLEM	POSSIBLE CAUSES	CORRECTIVE ACTION
1. SUDDEN OR RAPID SPITTING	1. Drop in inlet pressure. 2. Sudden increase in downstream pressure Due to water hammer from quick closing shut-off valve installed downstream.	A. Install an in-line spring loaded check valve upstream of backflow. B. Install pressure reducing valve upstream of Backflow unit. C. Install in-line spring loaded check valve Downstream of backflow as close to source as possible, but not closer than 4 feet.
2. LIGHT INTERMITTENT DRIP	1. Slightly fouled #1 check.	A. Clean #1 check and turn check valve seal Ring over or replace.

Continuous discharge of the relief valve signifies a failure of some part of the device. To help determine the specific area of failure, close the shut-off valve. If the discharge stops, the #2 check requires service. If the discharge continues, the #1 check requires service.

1. CONTINUOUS DISCHARGE	1. Fouled #1 check. 2. Fouled relief valve seat. 3. Fouled #2 check.	A. Clean check valves and turn check valve seal rings over or replace. B. Clean relief valve seat and turn relief valve Seal ring over or replace.
-------------------------	--	---

In summation, the amount of discharge is proportional to degree of fouling. Most problems occur in the #1 check which is where debris enters the backflow preventer first.

Repair Kit

RELIEF RUBBER ONLY	RELIEF COMPLETE	CHECKS ONLY
RK212-375R	RK212-375	RK212-350

MODEL FHZD 3" HYDRANT BACKFLOW METER

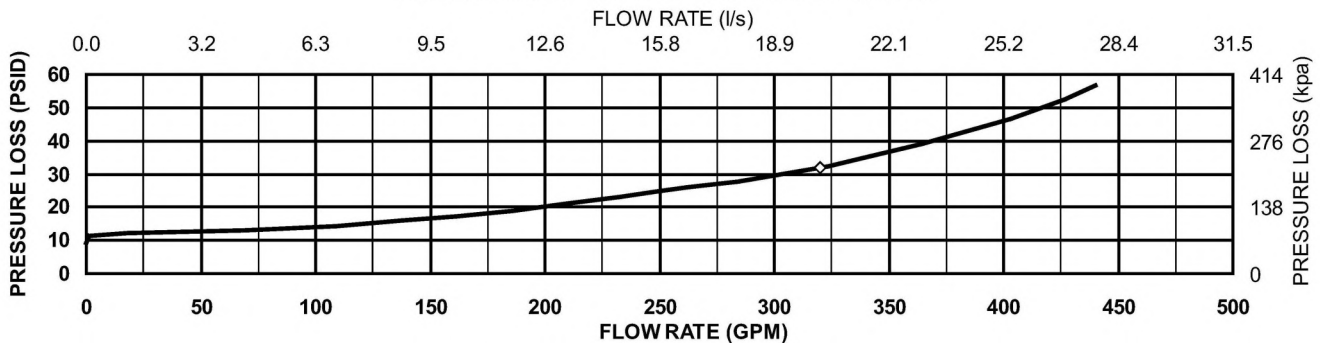

FHZD Repair Parts

ITEM	PART NUMBER	DESCRIPTION	QTY	ITEM	PART NUMBER	DESCRIPTION	QTY
1A	.04C20MSPS	Screw Slot Pan SS M4-0.7 x 20	2	18	FHZP-STR-SCR	Strainer Screen Assembly, SS	1
1B	.04C20MSPS-DH	Screw Slot Pan SS M4-0.7 x 20, DH	1	19	.06C10WLSS	Washer Lock SS M6	3
2	FHZ-CVRA-XB	FHZ Brass Shroud and Lid Assembly	1	20	.06C10HCSS	Bolt Hex Cap SS M6-1 x 10	3
2A	PM-RCVR-XB	Register Cover, Brass	1	21	NP2530B	Nipple 2.5"NH x 3"MIP, Brass	1
2B	PINOBR-098-100	Register Cover Hinge Pin	1	22	FHZD-RHSG-PBL5	FHZD Rear Housing	1
2C	FHZ-SHR-B	FHZ Brass Shroud	1	23	006-0355-4	O-Ring, Housing Front & Rear Seal	2
3	.04C6MPPS	Screw Phil Pan SS M4-0.7 x 6	2	24	3507-300A	3" Check Valve #2	1
4	FHZ-REG-RR	FHZ Register Retaining Ring, Plastic	1	25	3707-300	3" Check Valve #1	1
5-CF	FHZ03-REG-CF	FHZ Register, 3", Cubic Feet	1	26	FHZD-FHSG-PBL5	FHZD Front Housing	1
5-CM	FHZ03-REG-CM	FHZ Register, 3", Cubic Meters	1	27	SW2530B-STR	Swivel 2.5"SW x 3"MIP w/ Strainer	1
5-US	FHZ03-REG-US	FHZ Register, 3", U.S.Gallon	1	27A	SWG25-187	Swivel Gasket for 2-1/2" Swivel	1
6A	.12C40HCSS	Bolt Hex Cap SS M12-1.75 x 40	3	28	ZHSD-STAND	FHD Hydrant Meter Stand Assembly	1
6B	.12C40HCSS-DH	Bolt Hex Cap SS M12-1.75 x 40, DH	1	29	.10N20WSHS	Washer Flat SS M12 x 20 OD	2
7	.12N20WSHS	Washer Flat SS M12 x 20 OD	4	30	.10C25HCSS	Bolt Hex Cap SS M10-1.5 x 25	2
8	FHZ-HNDL-DS	FHZ Double Handle, SS	2	31	006-0032-4	O-Ring EPDM 1/16 W 1.864 ID	1
9	FHZ-CVRPL-PBL5	FHZ Cover Plate, Flat, Blue P.C.	1	32	3707-CU	Control Unit	1
10	FHZ-MEC	FHZ Measuring Element Components	1	33	3707-38C	Fitting, Elbow, 1/4NPT x 3/8 Comp	1
10A	FHZ-ME-FS	FHZ Measuring Element Front Seal	1	34-1	SFC-509-PP	Sensing Tube 3/8x3/8x9 Long Version	1
11	FHZ-CVRPL-ORING	FHZ Cover Plate O-Ring	1	34-2	KFC-507-PP	Sensing Tube 3/8x3/8x7 Short Version	1
12	FHZD-HSG-PBL5	FHZD Meter Housing	1	35	5758A-36	Sensing Tube Fitting	1
13	14-860FT	Test Cock, 1/4", Brass, w/Cap	3	36	.08C30CCSS	Bolt Socket Cap SS M8-1.25 x 30	18
14A	.08C30HCSS	Bolt Hex Cap SS M8-1.25 x 30	6	Misc	SEAL-TMP-PMT	Seal, Tamper, Twist-Lock	1
14B	.08C30HCSS-DH	Bolt Hex Cap SS M8-1.25 x 30, DH	2		002-6330	Tamper Seal Wire	1
15	.08N16WSHS	Washer Flat SS M8 x 16 OD	26		FHZD03N-UME-CF	Complete FHZD Unitized Measuring Element Assembly, includes items 1,2,3,4,5,9,10,10A, and 11	
16	FHZD-STR-CVR-PBL5	FHZD Strainer Cover	1		FHZD03N-UME-CM		
17	FHZP-STR-GSKT	FHZP Strainer Gasket	1		FHZD03N-UME-US		

